

POLY FLEX MOUNTS

Installation INSTRUCTIONS

MATERIAL SPECIFICATION

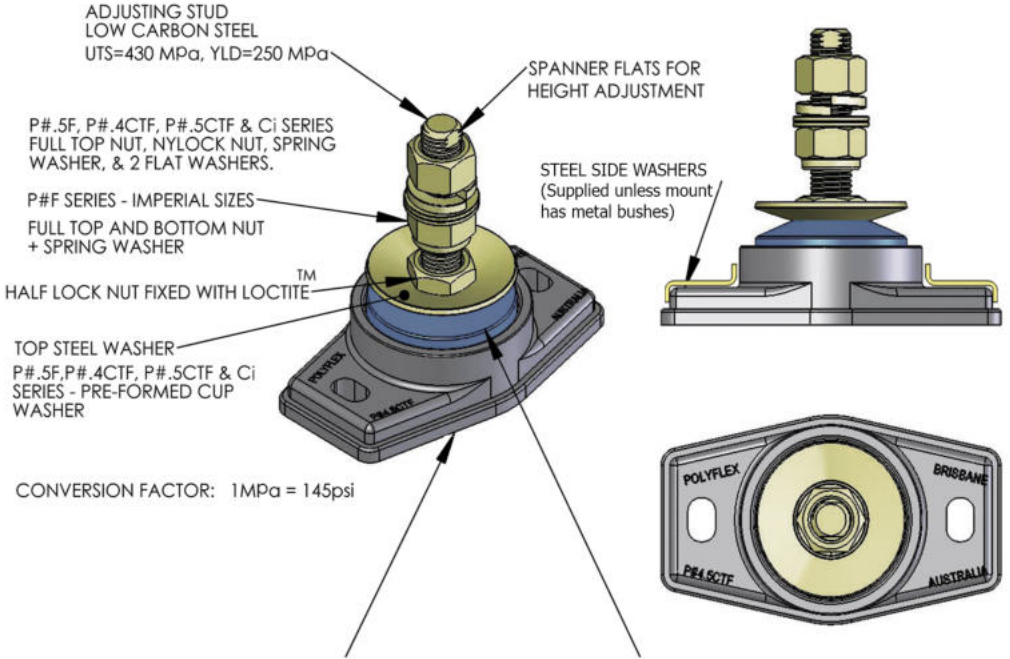

	Base		Core				
Polymer Code	75D	50A	60A	70A	80A	90A	95A
Shore Hardness Scale	75-D	50-A	60-A	70-A	80-A	90-A	95-A
Tensile Strength - psi	7542	4482	5076	4786	4786	6092	6527

Installation OF POLY FLEX MOUNTS

'INSTALLATION NOTE I'

MOUNTS WITH OR WITHOUT BASE BUSHES

PLEASE NOTE:

Poly Flex mounts are designed as true MARINE PROPULSION ENGINE MOUNTS; with sufficient vertical deflection to obtain the desired vibration isolation, combined with minimum fore, aft and lateral deflection under the propulsion load and inertial loads due to sea conditions.

Therefore it is IMPERATIVE that the top of the engine bed is parallel to the base of the engine mounting bracket in all planes to avoid any pre-load on the mount base, stud and core assembly.

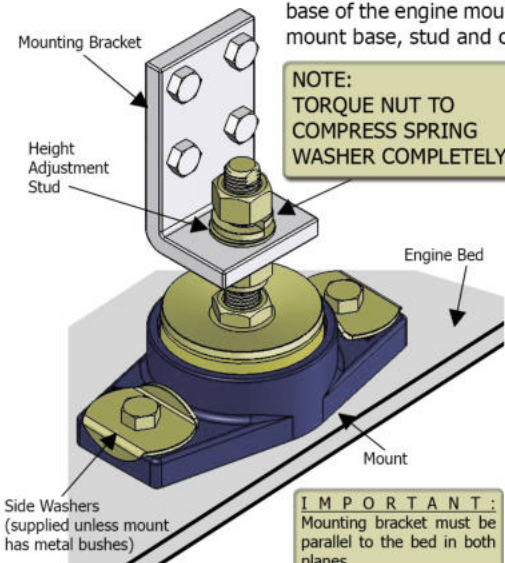

To check the above, simply remove the spring washer from the engine mount stud. Using the bottom adjusting nut and the top retaining nut, secure the mount to the engine mounting bracket in a fixed position. Ensure that the base of the mount is approximately 0.005" (0.127mm) above the engine bed. Check with a feeler gauge that there is an even 0.005" (0.127mm) gap around the base of the mount.

If so, release the mount, replace the spring washer and simply bolt the mount into position using the recommended torque settings, as shown in the table below.

If not, it is necessary to modify the engine bed in accordance with the above requirements, making sure that the bed strength is not effected.

DO use large heavy gauge washers for the bolts on the mount base side fixing lugs. Side washers are provided except where there are metal inserts in which case you MUST provide washers.

DO keep the bottom adjusting nut (and therefore the mounting bracket), as close as possible to the lock nut while still maintaining the range of adjustment to permit correct alignment of the engine.

DO NOT over torque the side bolts (see table) or the centre stud hex nuts. (Bolts broken by stress fractures are not covered under warranty)

DO NOT wind the stud out of the mount to maximise length, as the stud is factory assembled with Loctite 243. (The warranty is void if the mount and stud assembly is dismantled in any way)

- if required, it may be necessary to modify the engine bed or mounting bracket in accordance with the above requirements to allow the proper position on the mount stud to be obtained.

NOTE: Flats machined in top of stud to allow the stud to be held in place with a spanner while the nyloc nut is adjusted for the correct height, and for the final tightening of the top nut.

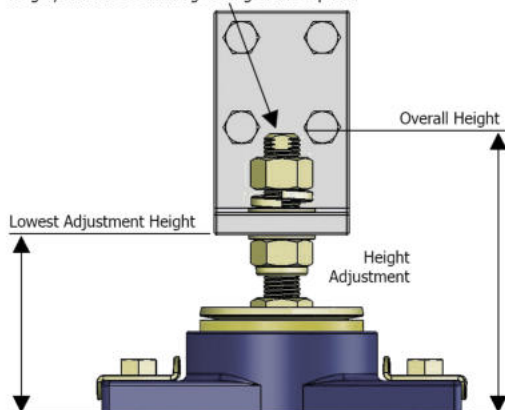

SIDE MOUNTING BOLT (not supplied)	
Recommended tightening torque settings	
BOLT SIZE	TORQUE SETTINGS
	Min - Max (lbf-ft)
M8	5 - 10
M10 (3/8")	10 - 15
M12 (1/2")	15 - 20
M16 (5/8")	35 - 40
M20	40 - 45

Installation OF POLY FLEX MOUNTS

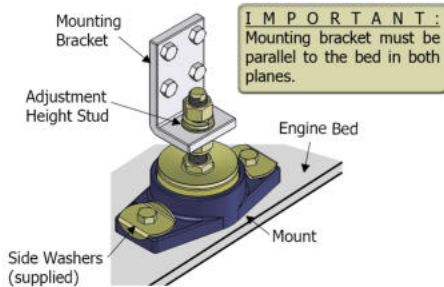

IMPORTANT:
Mounting bracket must be parallel to the bed in both planes.

NOTE: Flats machined in top of stud to allow the stud to be held in place with a spanner while the nyloc nut is adjusted for the correct height, and for the final tightening of the top nut.

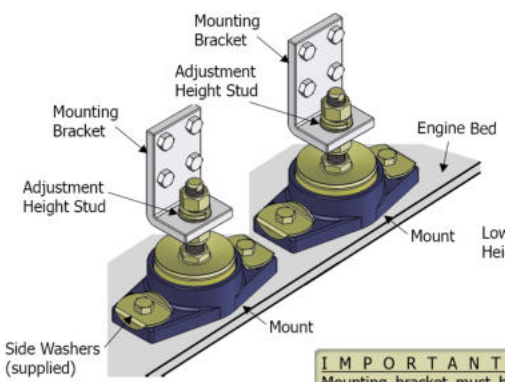
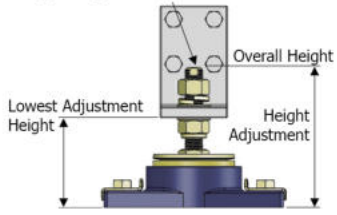

IMPORTANT:
Mounting bracket must be parallel to the bed in both planes.

NOTE: Flats machined in top of stud to allow the stud to be held in place with a spanner while the nyloc nut is adjusted for the correct height, and for the final tightening of the top nut.

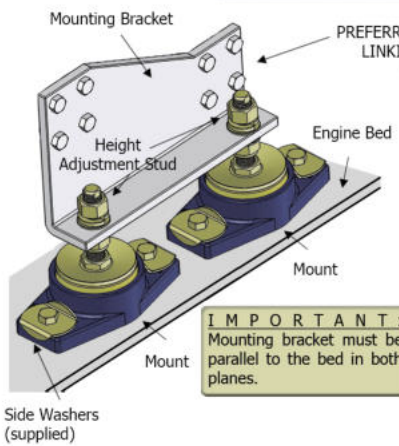
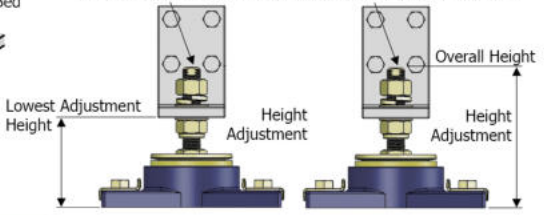

PREFERRED METHOD OF MOUNTING 2X MOUNTS WITH LINKING PLATE BETWEEN THE ENGINE AND THE MARINE GEAR. (REFER TO MANUAL)

IMPORTANT:
Mounting bracket must be parallel to the bed in both planes.

NOTE: Flats machined in top of stud to allow the stud to be held in place with a spanner while the nyloc nut is adjusted for the correct height, and for the final tightening of the top nut.

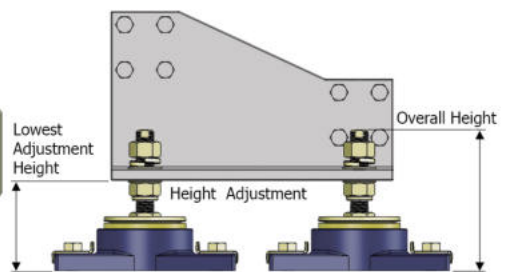

Installation OF POLY FLEX MOUNTS

'INSTALLATION NOTE 2'

POSITION OF MOUNTS RELATIVE TO CRANKSHAFT HEIGHT

FOR ALL APPLICATIONS INCLUDING MARINE PROPULSION AND GENSET TYPES. GENSET SHOWN IN THIS EXAMPLE.

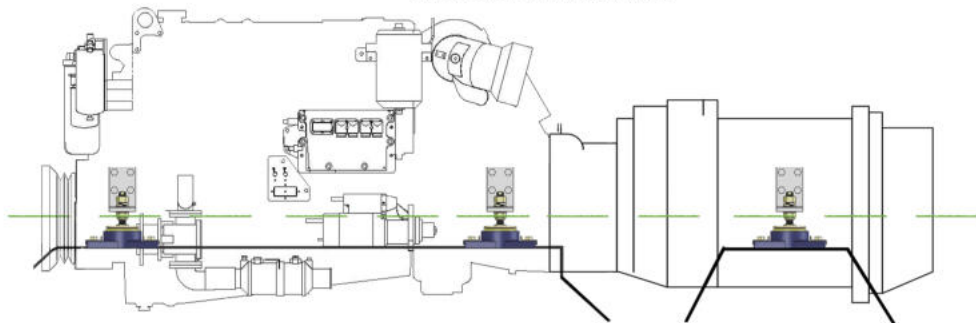

IMPORTANT NOTE

The mounts should always be placed as close as possible to the crankshaft centre line height (as shown)

If the engine needs to be raised up from the hull, the engine beds should be raised by the corresponding height to obtain the necessary relationship with the crankshaft.

FAILURE TO ACHIEVE THE ABOVE REQUIREMENTS WILL RESULT IN OVER-STRESSING THE MOUNTS AND THEREFORE REDUCING THE EFFECTIVE SERVICE LIFE OF THE PRODUCT.

INERTIAL FORCES DUE TO ROLLING MOTION IF ENGINE ALIGNED FORE & AFT OR DUE TO PITCHING MOTION IF ALIGNED ATHWARTSHIPS.

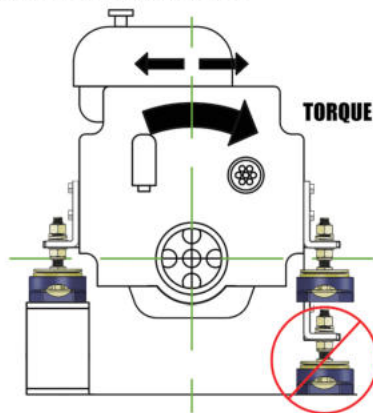

INSTALLATION OF POLY FLEX MOUNTS:

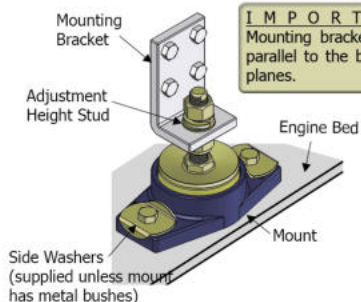

IMPORTANT: Mounting bracket must be parallel to the bed in both planes.

NOTE: Flats machined in top of stud to allow the stud to be held in place with a spanner while the nyloc nut is adjusted for the correct height, and for the final tightening of the top nut.

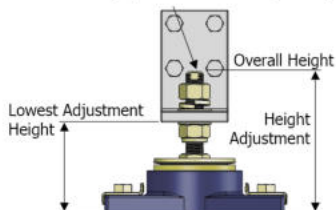

Installation OF POLY FLEX MOUNTS

'INSTALLATION NOTE 2'

POSITION OF MOUNTS RELATIVE TO CRANKSHAFT HEIGHT

FOR ALL APPLICATIONS INCLUDING MARINE PROPULSION AND GENSET TYPES.
DOWN ANGLE PROPULSION ENGINE SHOWN IN THIS EXAMPLE.

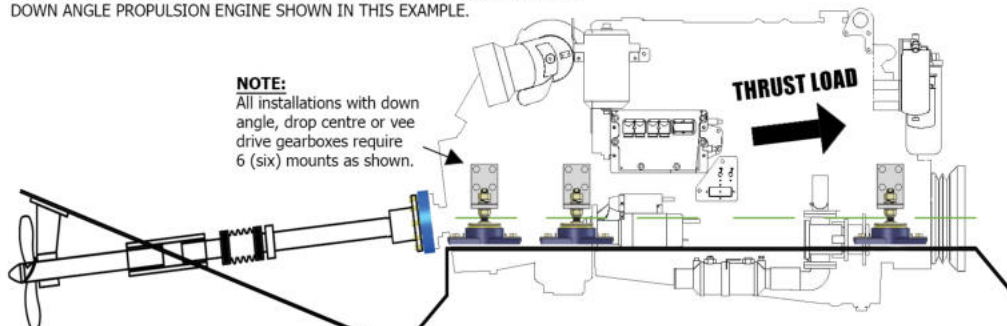

IMPORTANT NOTE

The mounts should always be placed as close as possible to the crankshaft centre line height (as shown)

If the engine needs to be raised up from the hull, the engine beds should be raised by the corresponding height to obtain the necessary relationship with the crankshaft.

Correct alignment of the propeller shaft with the gearbox output flange is of critical importance and should be carried out by experienced persons.

FAILURE TO ACHIEVE THE ABOVE REQUIREMENTS WILL RESULT IN OVER-STRESSING THE MOUNTS AND THEREFORE REDUCING THE EFFECTIVE SERVICE LIFE OF THE PRODUCT.

INERTIAL FORCES DUE TO ROLLING MOTION

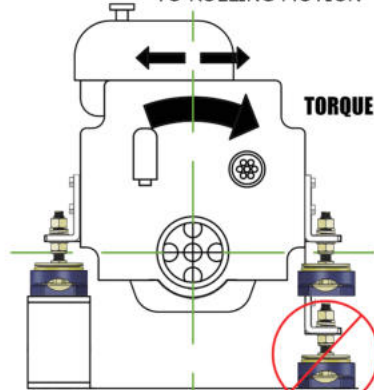

INSTALLATION OF POLY FLEX MOUNTS:

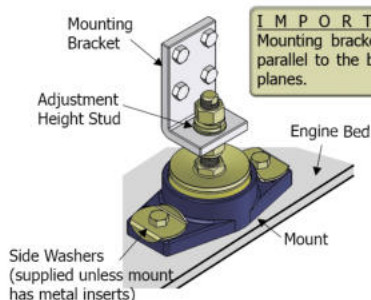

IMPORTANT:
Mounting bracket must be parallel to the bed in both planes.

NOTE: Flats machined in top of stud to allow the stud to be held in place with a spanner while the nyloc nut is adjusted for the correct height, and for the final tightening of the top nut.

